

Brian Blais' Quick Homemade Guide to Circuits

1 Initial Equations and Concepts

- Current, I . Units: *amps*
 - rate of flow of charge: $I = \Delta Q / \Delta t$
 - Potential difference, V . Units: *volts*
 - Resistance, R . Units: *ohms*
-

- Ohm's Law: $V = IR$

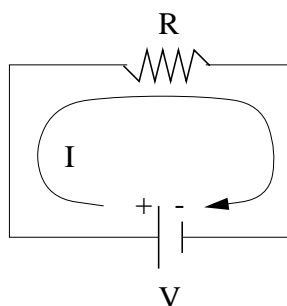

- The potential drop, V , across a resistor is the product of its resistance, R , and the current passing through it, I .
 - A nice analogy is a hose with gravel in it. The pressure of the water is the analog of the voltage, the total amount of water flowing through per second is the analog of the current, and the amount of gravel is the analog of the resistance. The more gravel (resistance), while maintaining the same pressure (voltage), yields *less water flow (current)*.
- Power (energy per time=watts) dissipated in a resistor: $P = IV = I^2R = \frac{V^2}{R}$. Light bulbs are resistors, and are brighter when more power is dissipated.
-

- In the symbols, the battery has a positive and negative terminal denoted as a long and a short line, respectively. The potential difference between the positive terminal and the negative one is V . Current flows *away* from the positive terminal, and *towards* the negative terminal through the wire, not across the gap of the battery.
- Anything connected by a wire is *at the same potential*, or there is *no potential difference* along a wire. Any points that are at the same potential can be replaced by a single wire. Wires can be *any* shape we want, which we will use to our advantage later
- Circuit elements in *series* have the *same current* flowing through them
- Circuit elements in *parallel* have the *same potential difference* across them
- Equivalent resistances

- In series: $R_{\text{eq}} = R_1 + R_2 + R_3 + \dots$
 - In parallel: $\frac{1}{R_{\text{eq}}} = \frac{1}{R_1} + \frac{1}{R_2} + \frac{1}{R_3} + \dots$
-

- Kirchoff's Laws

- The *Node Rule*, a.k.a. conservation of charge: at an intersection of wires (node) the total amount of current flowing in equals that flowing out
- The *Loop Rule*, a.k.a. conservation of energy: the potential drop around *any* current loop is *zero*. This just means that if you go walking, and you come back to the same place, you haven't changed your net elevation. Everytime you went uphill you had to go downhill by the same amount at some point to arrive back where you started

2 Example

In this example I will find the current *through* each of the resistors, and the potential drop *across* each of them. Remember, current is how much charge is passing through the resistor per second. Potential drop is the change in potential from one side of the resistor to the other. I will outline the two main recipes for approaching these types of problems.

Example 1

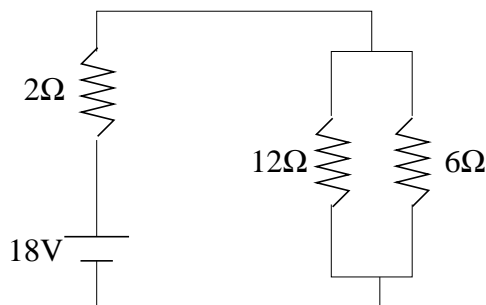

Recipe without Kirchoff's Laws:

1. Combine resistances in parallel and those in series, making sure to redraw the circuit each time
2. Reduce the problem to the single resistor case shown first
3. Figure out the current and voltage drop across the one equivalent resistor using Ohm's law
4. Move backwards through your circuit diagrams, expanding one-by-one the series/parallel combinations.
 - When expanding an equivalent resistance to two in series, each new resistor has the *same current* flow as the equivalent resistance. The voltage drop across each one would be given by $V_1 = IR_1$ and $V_2 = IR_2$.
 - When expanding an equivalent resistance to two in parallel, each new resistance has the *same potential drop* across it as was across the equivalent resistor. The current in each one would then be given by $I_1 = V/R_1$ and $I_2 = V/R_2$.

5. Repeat this process through the entire circuit to get all of the currents and potential drops for each resistor. Now you can tell which light bulb would be brighter, if the resistors were light bulbs.

Let's use the recipe:

1. Combine resistances in parallel and those in series, making sure to redraw the circuit each time

Two Resistances in parallel:

$$\frac{1}{R_{eq1}} = \frac{1}{12\Omega} + \frac{1}{6\Omega} = \frac{1}{4\Omega}$$

$$R_{eq1} = 4\Omega$$

Two Resistances in series:

$$R_{eq2} = 2\Omega + 4\Omega$$

$$R_{eq2} = 6\Omega$$

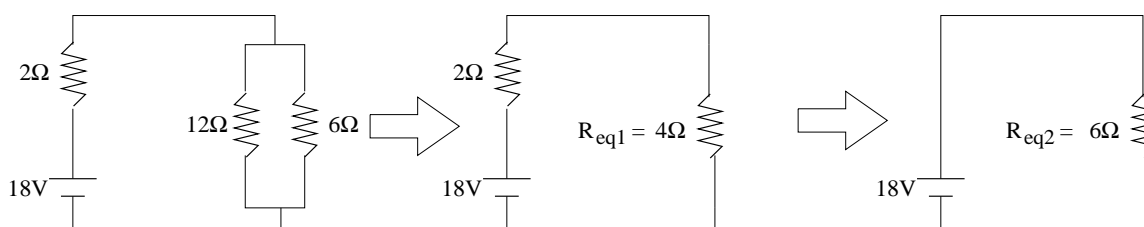

2. Reduce the problem to the single resistor case shown first
3. Figure out the current and voltage drop across the one equivalent resistor using Ohm's law
Current through R_{eq2} is $18V/6\Omega = 3A$
4. Move backwards through your circuit diagrams, expanding one-by-one the series/parallel combinations.
- When expanding an equivalent resistance to two in series, each new resistor has the *same current* flow as the equivalent resistance. The voltage drop across each one would be given by $V_1 = IR_1$ and $V_2 = IR_2$.
 - When expanding an equivalent resistance to two in parallel, each new resistance has the *same potential drop* across it as was across the equivalent resistor. The current in each one would then be given by $I_1 = V/R_1$ and $I_2 = V/R_2$.

Expanding R_{eq2} to the 4Ω and 2Ω resistors in series: the current is the same as through R_{eq2} , or $I = 3A$. The potential drop across the 2Ω resistor is then $3A \cdot 2\Omega = 6V$. The potential drop across the 4Ω resistor (R_{eq1}) is then $3A \cdot 4\Omega = 12V$.

Expanding R_{eq1} to the 6Ω and 12Ω resistors in parallel: the potential drop is the same as that across R_{eq1} , or $V = 12V$. The current through the 6Ω is then $12V/6\Omega = 2A$. The current through the 12Ω is then $12V/12\Omega = 1A$.

5. Repeat this process through the entire circuit to get all of the currents and potential drops for each resistor. Now you can tell which light bulb would be brighter, if the resistors were light bulbs.

The following table summarizes the results:

Resistance	Voltage Drop	Current	Power Dissipated
2Ω	6V	3A	18W
12Ω	12V	1A	12W
6Ω	12V	2A	24W

It is clear to see that the 6Ω would be the brightest lightbulb, if these resistors were light bulbs. The 2Ω would be next brightest, and the 12Ω would be the dimmest.

Sometimes the problem is not easily reduced, as this one is, so you need a method that will work on those as well. That's where Kirchoff's Laws come in. In many ways it is a method which requires more work, but it is guaranteed to work on hard problems, and it is completely straightforward once you have the recipe down.

Recipe with Kirchoff's Laws:

1. Draw arrows for all the currents in the problem, and label them like I_1 , I_2 , etc.
 - Try to get the direction correct (e.g. away from the positive terminal of a battery), but don't get stressed about it: if you get it wrong, you will just get a negative current.
 - Anytime you have a junction of wires, a node, the current splits along each one and has a different magnitude, and thus a different label
 - The current through elements in series is the same, so there is only one label or one current arrow
2. Imagine a path in the circuit which starts at some place, and ends up back at that place. In your mind, walk around the path without backtracking, and add up the following potential drops everytime you pass them, and set the sum to zero:

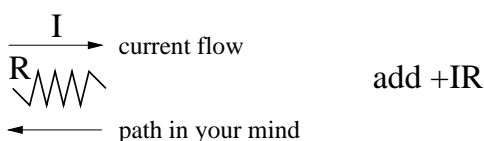
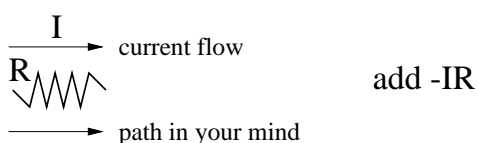
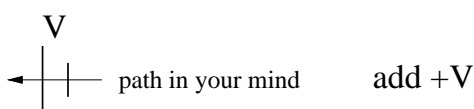
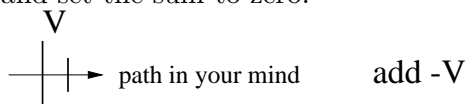

3. At a node, add up all the current and set equal to zero. Current flowing *into* the node is *positive*, while current flowing *away* from the node is *negative*
4. Use enough nodes and paths to get enough equations to solve for all your unknowns, and solve. This step can get algebraically messy.

5. Use the current information from the previous step to calculate the potential drops across each resistor

Let's use the recipe:

1. Draw arrows for all the currents in the problem, and label them like I_1 , I_2 , etc.

Though I probably got the directions mostly correct, I purposely made I_3 go in the opposite direction I thought it would go, to demonstrate that it really doesn't matter if you get it totally correct.

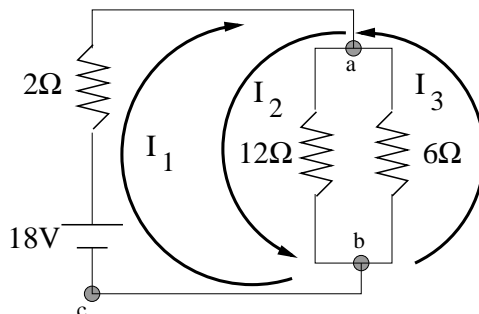

2. Imagine a path in the circuit which starts at some place, and ends up back at that place. In your mind, walk around the path without backtracking, and add up the potential drops everytime you pass them, and set the sum to zero.

One possible path starts at point c , goes through the battery, the 2Ω resistor, point a , the 6Ω resistor, point b , and back to point c . Looking at the chart of potential drops, I get the following equation from that path:

$$+18V - 2\Omega \cdot I_1 + 6\Omega \cdot I_3 = 0$$

3. At a node, add up all the current and set equal to zero. Current flowing *into* the node is *positive*, while current flowing *away* from the node is *negative*

At point a we get the following equation:

$$I_1 + I_3 - I_2 = 0$$

4. Use enough nodes and paths to get enough equations to solve for all your unknowns, and solve.

We need 3 equations to solve for the 3 unknowns, so let's choose another path. Let's use one that starts at point c , goes through the battery, the 2Ω resistor, point a , the 12Ω resistor, point b , and back to point c . This path yields

$$+18V - 2\Omega \cdot I_1 - 12\Omega \cdot I_2 = 0$$

We now have the following equations:

$$\begin{aligned} +18V - 2\Omega \cdot I_1 + 6\Omega \cdot I_3 &= 0 \\ I_1 + I_3 - I_2 &= 0 \\ +18V - 2\Omega \cdot I_1 - 12\Omega \cdot I_2 &= 0 \end{aligned}$$

Solving them gives us

$$\begin{aligned}
 +6\Omega \cdot I_3 &= -12\Omega \cdot I_2 \Rightarrow I_3 = -2I_2 \\
 I_1 - 3I_2 &= 0 \Rightarrow I_1 = 3I_2 \\
 +18V - 2\Omega \cdot 3I_2 - 12\Omega \cdot I_2 &= 0 \\
 &= +18V - 18\Omega \cdot I_2 \Rightarrow I_2 = 1A
 \end{aligned}$$

which then gives the results we found previously:

$$\begin{aligned}
 I_2 &= 1A \\
 I_1 &= 3I_2 = 3A \\
 I_3 &= -2I_2 = -2A \text{ (we drew the wrong direction here, so it came out negative)}
 \end{aligned}$$

3 Exercises

- Find the current, potential drop, and power dissipated for each resistor in the following 2 circuits. Use whatever method.

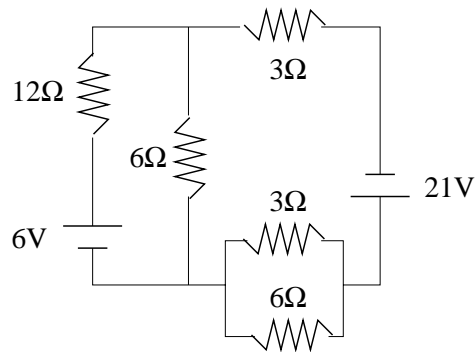
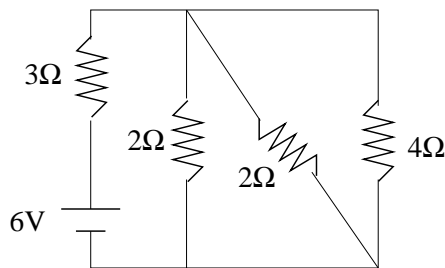

- Is it better to hook up christmas tree lights in series or parallel? What is the advantage to each?
- If, in the first circuit of the Exercises, the resistors are lightbulbs and we rip out the 4Ω resistor, what happens to the brightness of the others?
- If you had a 9V battery, and a 100Ω resistor in a circuit, how long would it take to heat a cup of coffee? Melt a snowball?